



USN

--	--	--	--	--	--	--	--	--	--	--	--

10CV/CT73

Seventh Semester B.E. Degree Examination, Jan./Feb. 2021

Estimation and Valuation

Time: 3 hrs.

Max. Marks:100

Note: 1. Answer full question from PART – A.**2. Answer FOUR questions selecting at least TWO full questions each from Part B and C.****3. Assume missing data suitably, if any.****PART – A**

- 1 Prepare a detailed estimate for a residential building shown in Fig.Q1(i) and Fig.Q1(ii) for the following items of work. Prepare abstract also:
- (i) Earth work in excavation for foundation in hard soil at Rs.210/m³
 - (ii) C.C. bed 1:4:8 in foundation at Rs.4250/m³
 - (iii) SSM with CM 1:4 in foundation and basement at Rs.4500/m³
 - (iv) C.C. Plinth 1:2:4 at Rs.4800/m³
 - (v) BBM walls with C.M. 1:6 for super structure at Rs.4000/m³. **(40 Marks)**

PART – B

- 2 Prepare a detailed estimate of septic tank with soak pit shown in Fig.Q2 for following items of work.
- (i) Earth work in excavation.
 - (ii) I class Brick Work
 - (iii) 12 mm thick cement plastering of walls. **(15 Marks)**
- 3 a. List different types of estimate. Explain any two. **(08 Marks)**
b. Explain different types of contracts briefly. **(07 Marks)**
- 4 Write detailed technical specifications for any three of the following:
- (i) C.C. in foundation 1:4:8
 - (ii) R.C.C. (1:2:4) in roof slab
 - (iii) D.P.C. 2.5 cm thick (1: 1½ : 3)
 - (iv) Mosiac flooring **(15 Marks)**

PART – C

- 5 Carry out rate analysis for three of the following from first principle;
- (i) C.C. 1:5:8 for bed in foundation
 - (ii) Random rubble stone masonry
 - (iii) BBM in super structure with 1:6 C.M
 - (iv) Plastering 12 mm thick in C.M. 1:6 **(15 Marks)**
- 6 Estimate the cost of earth work for portion of road from following data by mean sectional area method. Road width = 8m, side slope 2:1 in banking and 1½ : 1 in cutting, length of chain 30m.

Chainage	20	21	22	23	24	25	26	27	28	29	30
Ground level	71.2	71.25	70.9	71.25	70.8	70.45	70.2	70.35	69.10	69.45	69.70
Formation level	70	← upward gradient 1 in 200 →									

(15 Marks)

- 7 Write short notes on any three:
- (i) Administrative approval
 - (ii) EMD
 - (iii) Measurement book
 - (iv) Schedule of rates
 - (v) Valuation and different methods of valuation

(15 Marks)

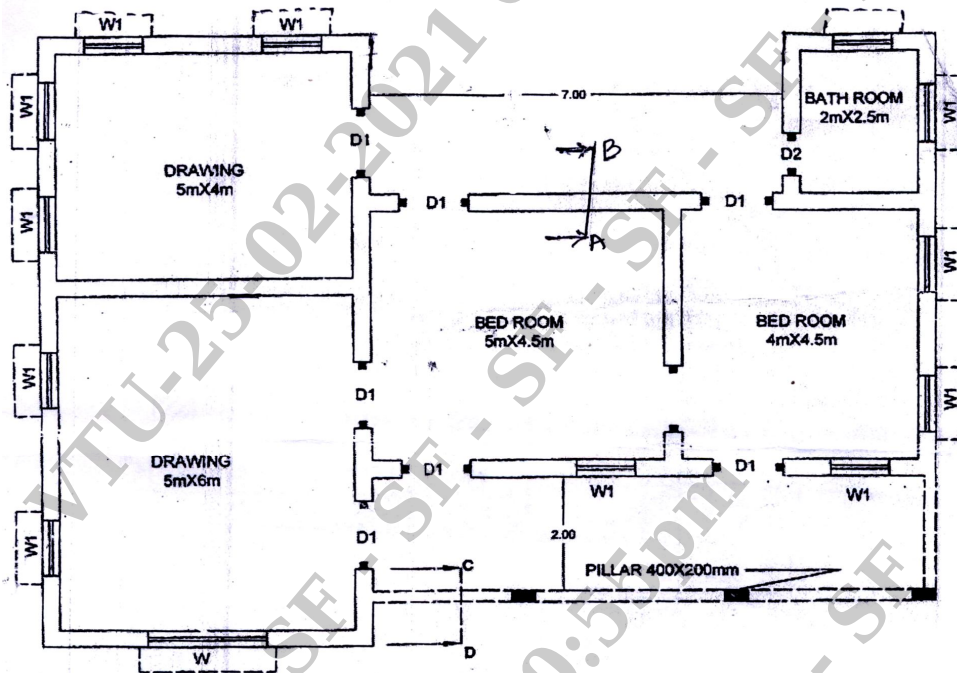
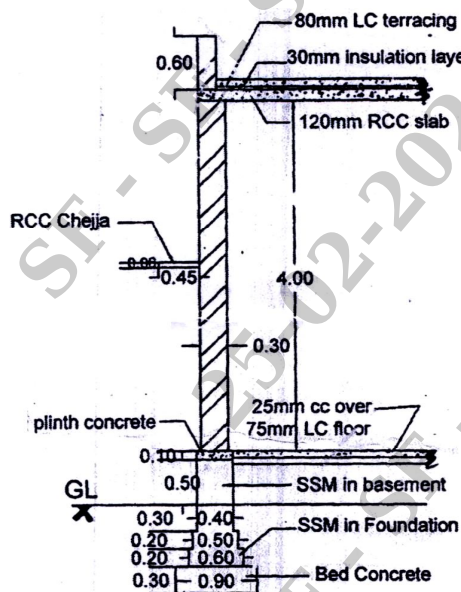
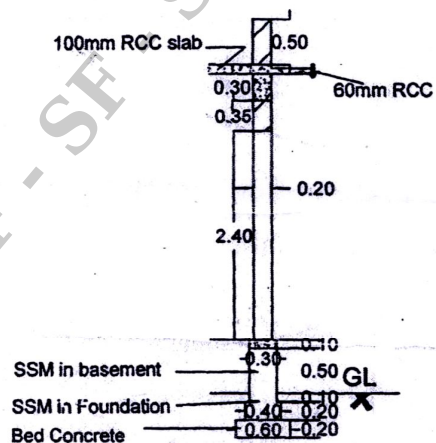

Fig.Q1(i)



SECTION ON AB



SECTION ON CD

INDEX

DOORS

D1 - 1.2x2.1

D2 - 1.0x2.1

WINDOWS

W - 2.0x1.5

W1 - 1.0x1.5

W2 - 0.75x1.2

Fig.Q1(ii)

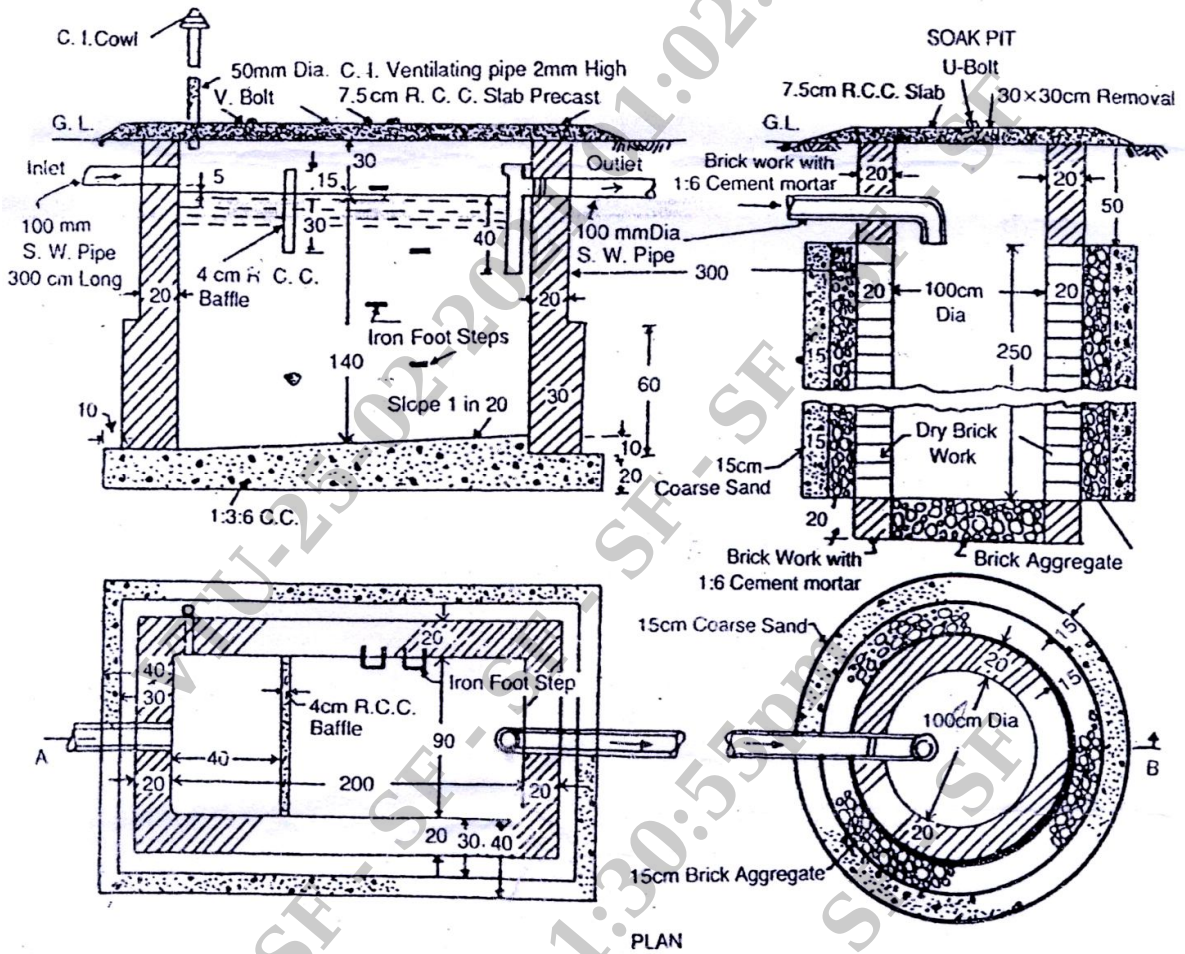

All Dimensions in Centimetre unless otherwise Specified

Fig.Q2

* * * * *